

Installation Guidelines For Murray Pex Pinch Clamps

Murray Pex Pinch Clamps should be installed in accordance with local plumbing codes and practices.

Murray Pex Pinch Clamps are designed for use with pex tubing (specification ASTM F876 and/or CSA B137.5), and metal insert fittings (specification ASTM F877 and F1807).

An approved tool (Murray A4000 ratchet style tool or equivalent style tool meeting ASTM F-2098 specifications) should be used to install Murray Pex Pinch Clamps. The use of a non-approved tool could result in improper installation of the Clamp, and a poor connection.

Because pex tubing stiffens as ambient temperature decreases, it is recommended that Murray Pex Pinch Clamps be installed at temperatures of 35 degrees Fahrenheit and above, to ensure proper sealing performance.

Installation of Murray Pex Pinch Clamps:

1. Keep all components clean until ready for use. Dirt, water, or other contaminants on mating contact surfaces of the Clamp, tubing or fitting can result in an inferior assembly. When in doubt, wipe clean the contact surfaces of the components before assembly.
2. Fresh cut the tube end so that it is square, using a sharp cutter to ensure the tube is not deformed.
3. Slide Clamp over tube end, and insert fitting fully.
4. Align Clamp so that it is 1/8" to 3/16" from cut end of tube.
5. Crimp Clamp fully closed with tool. The ratchet in the tool will not allow the tool to open until the Clamp is fully closed.
6. Visually verify that Clamp has been fully closed. Maximum root gap in ear of Clamp after crimping is 0.080" (measure using Murray Gage G386). If the gap exceeds this limit, the tool is worn and should be replaced, and the existing joint should be re-prepared as above, using a new Clamp. Note that tool wear is a slow and gradual process, and it is not necessary to measure the crimped root gap in each Clamp installed. Measuring the root gap on several Clamps at the beginning of the workday, and several in the afternoon, should be adequate to apprise the installer of the tool's condition.

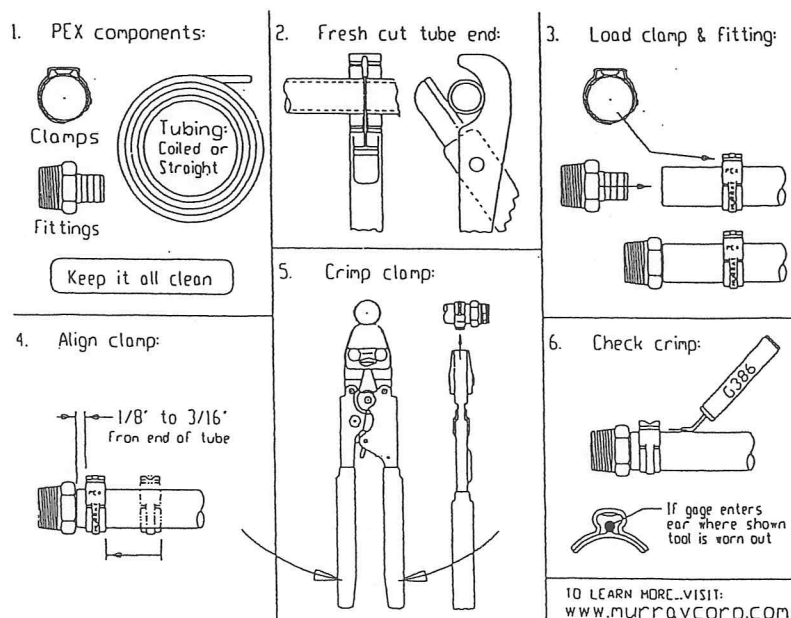

Murray Corporation
260 Schilling Circle
Hunt Valley, Maryland, USA 21031
Phone 410-771-0380
Website www.murraycorp.com

Revised 5/15/07