

MURRAY

MURRAY CORPORATION Clamping Solutions

Spring-Loaded T-Bolt Clamps - SAE Type "SLTB"

Murray spring-loaded clamps are designed to compensate for the expansion and contraction of hose caused by temperature and/or hose cold flow. Typical installations include silicone hoses on charge air cooling/air to air, after cooling systems, and primary engine coolant systems. Locknut rated temp. 250°F

TBLS series clamps use a plated steel self-locking nut, bolt and spring. The balance of the components are made from 300 series stainless steel. Band edges are rounded to protect hoses.

Maximum service temperature for locknut is 250° (F).



Note: Coil springs should not be compressed to solid at installation. Make sure the nut is positioned approximately one to two turns from solid. This allows the clamp to expand and contract.

Rated Ultimate Torque:

Plated Steel Bolt & Nut: 90in.lbs. min. (10.2Nm)

Recommended Installation Torque:

Plated Steel Bolt & Nut: 50-60in.lbs. (5.6 - 6.8Nm)

300 Series Stainless Bolt & Nut: 50-60in.lbs. (5.6 - 6.8Nm)

Double Plated Nut & Bolt Spring	Inches			Millimeters		
	Nominal	Min.	Max.	Nominal	Min.	Max.
TBLS132	1.25	1.12	1.32	32	28	34
TBLS145	1.40	1.26	1.45	36	32	37
TBLS169	1.60	1.50	1.69	41	38	43
TBLS212	2.00	1.82	2.12	51	46	54
TBLS236	2.25	2.06	2.36	57	52	60
TBLS261	2.50	2.31	2.61	64	59	66
TBLS286	2.75	2.56	2.86	70	65	73
TBLS308	3.00	2.78	3.08	76	71	78
TBLS333	3.25	3.03	3.33	83	77	85
TBLS358	3.50	3.28	3.58	89	83	91
TBLS383	3.75	3.53	3.83	95	90	97
TBLS408	4.00	3.78	4.08	102	96	104
TBLS433	4.25	4.03	4.33	108	102	110
TBLS458	4.50	4.28	4.58	114	109	116
TBLS483	4.75	4.53	4.83	121	115	123
TBLS508	5.00	4.78	5.08	127	121	129
TBLS533	5.25	5.03	5.33	133	128	135
TBLS558	5.50	5.28	5.58	140	134	142
TBLS586	5.75	5.56	5.86	146	141	149
TBLS608	6.00	5.78	6.08	152	147	154
TBLS633	6.25	6.03	6.33	159	153	161
TBLS655	6.50	6.25	6.55	165	159	166
TBLS686	6.75	6.56	6.86	171	167	174
TBLS708	7.00	6.78	7.08	178	172	180
TBLS736	7.25	7.06	7.36	184	179	187
TBLS758	7.50	7.28	7.58	191	185	193
TBLS783	7.75	7.53	7.83	197	191	199
TBLS811	8.00	7.81	8.11	203	198	206
TBLS858	8.50	8.28	8.58	216	210	218
TBLS880	8.75	8.50	8.80	222	216	224

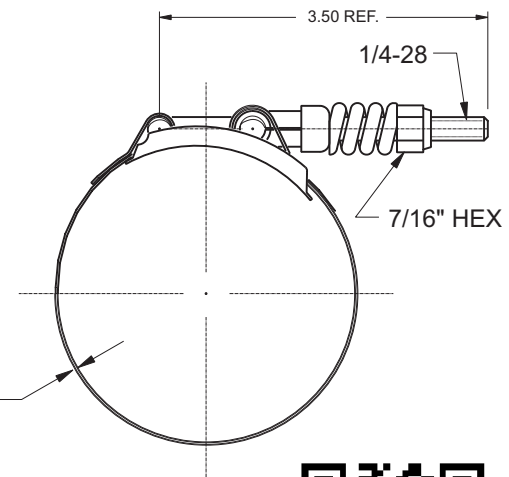
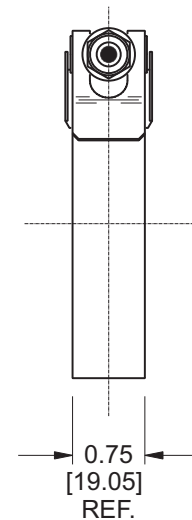

Other sizes, configurations and materials are available. Please contact the sales department for more information.
All items are packaged 50 pieces per carton.
Spring rate = 1900 lbs/in. capable of exerting a 300 lb. band load.

.025 REF.
[0.64]



260 Schilling Circle
Hunt Valley, MD, 21031, USA

Ph: 410-771-0380 • Fax: 410-771-5576

www.murraycorp.com • email: sales@murraycorp.com